

# Applying Design of Experiments Method for the Verification of a Hydropower System

Le Nam Hai Pham<sup>1</sup> Dietmar Winkler<sup>2</sup>

<sup>1</sup>University of South-Eastern Norway, Porsgrunn, Norway, Le.Pham@usn.no

<sup>2</sup>Department of Electrical Engineering, IT and Cybernetics, University of South-Eastern Norway, Porsgrunn, Norway, dietmar.winkler@usn.no

## Abstract

Today, renewable energy plays a major role in the transition towards environment-friendly energy sources. Hydropower is one of the most important renewable energy sources leading to the high interest of research associated with the development of new technologies. These technologies aim to examine and predict the characteristics and behaviour of hydropower plants during different operating conditions and are often associated with simulation models. In the progress of creating accurate simulation models, it is necessary to have an organised and systematic method to verify and optimise the model with the help of available data. This is where the “Design of Experiments” (DoE) principles should be applied.

A simulation model of a reference hydropower plant located in Seljord municipality in the south-east of Norway was implemented using the modelling language Modelica. All parts of this hydropower plant model were tuned according to DoE procedure with the purpose of design verification and optimisation. The results of the experiments are a complete and optimised hydropower plant model that gives reliable simulation results.

*Design of Experiments, DoE, hydropower, modelling, Modelica, OpenHPL*

## 1 Introduction

In the contemporary society, there is no denying that the use of renewable energy is an absolute must when it comes to trying to reduce the greenhouse effect and slow down climate change. Among renewable energy sources, hydropower has existed for hundreds of years and, depending on the geographical location, represents a large amount of the current electricity supply. According to IEA (International Energy Agency 2022), hydropower is remaining the largest renewable source of electricity, generating more than all other renewable technologies combined. Because of the large capability of producing electricity along with the clean, reliable and flexible advantages, research of hydropower is of the highest interest and is often associated with the development of new technologies. In the era of modelling and simulation, a hydropower plant simulation model is often built with the purpose of examining and predicting the characteristic and behaviour

of real plant during the different operating conditions.

In Norway, around 98 percent of all power generation comes from hydropower and Norway is one of the world’s largest electricity producer per capita (Energy 2016).

In cooperation with the company Skagerak Kraft AS, based in Porsgrunn, Norway, a hydropower system model of one of their power plants located in the south-east of Norway, Grunnåi power plant, was implemented in order to study the dynamic characteristics of the plant. In the progress of building the simulation model, it is necessary to have an organised and systematic method to verify and optimise the model with the help of as much measurement data as possible.

In the recent past, many researchers have investigated the methodology of verification and validation of simulation models (Sargent 2008; Kleijnen 1995). Most of them introduced basic approaches to help research community grasp the concept, but lack realistic cases or focus in a particular simulation model. To overcome this shortcoming, this paper contributes a methodology of verification and validation, focusing to real-world hydropower plant simulation model. This is where the “Design of Experiments” (DoE) principles should be applied to perform a series of experiments on the simulation model.

To build such model and implement different experiments of model verification, the object-oriented modelling language Modelica (Modelica Association 2021) is used to model the complex physical power plant. The commercial modelling and simulation environment Dymola was used. In addition, OpenHPL (OpenSimHub 2022), an open-source hydropower library that consists of hydropower unit models, was used for building the complete hydropower system.

## 2 Design of Experiment

The “Design of Experiments” (DoE) is a systematic, efficient methodology that can be effective for general problem-solving, as well as for improving or optimising product design and manufacturing processes. DoE includes a series of applied statistics tools used to systematically classify and quantify cause-and effect relations between variables and outputs in the studied process or phenomenon, which may result the finding the settings and conditions under which the process becomes opti-

mised (Jankovic, Chaudhary, and Goia 2021).

In DoE, a linear regression method, which is a linear approach for modelling the relationship between a scalar response and one or more explanatory variables, is broadly applied (Brownlee 2016). A general multiple linear regression model with one response and  $i$  regressor variables is expressed as:

$$y = \beta_0 + \beta_1 x_1 + \beta_2 x_2 + \dots + \beta_i x_i \quad (1)$$

where:

$y$  Response variable

$x_j, j=0,1,\dots,i$  Input variables or input factors

$\beta_{j,j=0,1,\dots,i}$  Regression coefficients or parameters, represents expected change in response variable per unit change in input variable

## 2.1 Basic Principles of DoE

### 2.1.1 Randomisation

Randomisation is the practice of using chance methods to assign treatments to experimental units in a manner that protects against unintended influences on the assignments. A treatment, which is one specific combination of several factors at specific levels, are applied to a set of experimental units to plan an experiment to ensure valid statistical analysis is possible. Randomisation allows experimenters to safeguard against unforeseeable and uncontrollable variables which might have mask relationships between the factors and the response (Emily Divis et al. 2020).

### 2.1.2 Replication

Replication means repetitions of the entire basic experiment or a portion of it under one or more conditions. In other words, it is a process of running the experimental trials in a random sequence. Replication is very principal because it adds information about the reliability of the conclusions or estimates to be drawn from the data. Therefore, it has two important properties.

These are:

- Allowing the experimenter to gain the experimental error estimation
- Permitting the experimenter to gain a more precise estimate of the factor/interaction effect

It is noted that if the number of replicates is equal to one or unity, the conclusions of the effect of the factors or interactions cannot be given. Therefore, it is necessary to have a sufficient number of replicates. (Antony 2014; eMathZone 2014)

### 2.1.3 Blocking

Blocking is a method of eliminating the effects of extraneous variation according to noise factors, thereby improving the efficiency of experimental designs (Antony 2014). In the statistical theory of the design of experiments, the experimental units in groups or blocks, which are similar to one other, are arranged. Generally, a blocking factor is a source of variability that is not of primary interest of the experimental designs (eMathZone 2014). Experimenters can collect data under the same experimental conditions in the same block and determine the variability between blocks from the experimental error, which increases the precision of the experiments (Antony 2014).

## 2.2 DoE steps

This section describes the steps to perform experiments on a hydropower plant simulation model which then are later implemented. To gain good results of experiments, the key steps of DoE can put into categories.

These are:

1. **Objective recognition:** A clear statement of the problem or the objectives for an experiment can be given to gain the understanding of what needs to be done. The statement should contain a specific and measurable objective that can optimise the practical value. Clearly defined goals or objectives of the experiments are important and influence the later steps of experiments. (Antony 2014)
2. **Selection of response:** The selection of a suitable response for the experiment is important to the success of the experiment. The response, or output of experiment which are potentially influenced by the factors and their respective levels, should be certain to provide the useful information about the process under study. (MoreSteam 2022)
3. **Selection of process variables:** This stage is dedicated to consider the factors or the inputs to the process that may influence the performance of a process or system. It is crucial for the experimental procedure since if the important factors are left out of the experiment, then the response of the experiment will not be accurate and useful for any later improvement action. (Antony 2014)
4. **Performing the experiment:** In this stage, the planned experiments are carried out and conducted. When running the experiment, it is vital to monitor the process carefully to ensure that everything is being done correctly according to the sequence of experiments.
5. **Interpreting experimental results and conclusions:** After the experiment is completed, the data gathered are interpreted. The experimental results carry out the practical conclusions of the experiments and recommendation for the next actions.

### 3 Grunnåi Power Plant

In the year 2006, a hydropower station was completed in the Seljord municipality, Telemark county, in the south-east of Norway. At this time, there was only one turbine installed, turbine 1 (T1), with the capacity of 15.1 MW and an annual production of 55 GWh. In 2019, to reduce the loss of energy production due to unused flood waters (over-spill), an extra turbine, turbine 2 (T2), with the capacity of 10.2 MW was installed and increased the annual production to 66 GWh. The two turbines are five-nozzle Pelton turbines that are regulated by the water level of the intake reservoir and associated inflow. Table 1 shows the general information of these turbines.

**Table 1.** The turbines nominal operation values, Grunnåi Power Plant.

<i>Turbine 1 (T1) Pelton type</i>		
<i>Property</i>	<i>Value</i>	<i>Unit</i>
Number of Nozzles	5	-
Nominal Head	385	<i>m</i>
Nominal flow rate	4.42	<i>m</i> <sup>3</sup> / <i>s</i>
Nominal Power	15	<i>MW</i>
Turbine Efficiency	90	<i>%</i>
<i>Turbine 2 (T2) Pelton type</i>		
Number of Nozzles	5	-
Nominal Head	389	<i>m</i>
Nominal flow rate	3.08	<i>m</i> <sup>3</sup> / <i>s</i>
Nominal Power	10.76	<i>MW</i>
Turbine Efficiency	91	<i>%</i>

#### 3.1 Geometry Data

The watercourse of hydropower station primarily runs through Seljord municipality and its outlet is from the east side of the valley at Vallaråi river in Flatdal. The water reservoir is Slååkåvatn lake on the Lifjell mountain. The reservoir is located 387 meters above the power plant and the rated discharged is at 7.5 m<sup>3</sup>/s. A rough sketch of the structure of Grunnåi power plant is depicted in Figure 1.

The water from reservoir is conveyed to the power plant by the waterway system containing different geometry parts (lengths, slope, etc.) consisting of two blasted tunnels, “1” and “2” that then connected with a steel pipe conduit “3”. This conduit is branched into two separate paths “4+5” and “6+7” into two respective turbines, “T1” and “T2”. Water discharged from two turbines through the respective outlet pipe “8” and “9” and flows to the downstream, Vallaråi river through outlet system containing outlet tunnel “10” connected with culvert “11”. The flow rate of water transfer through these units are commonly influenced by roughness parameter, however, this parameter is neglected in this paper. The general information of the waterway system’s elements can be seen in Table 2.

**Table 2.** The waterway geometry

<i>Element</i>	<i>Index</i>	<i>Length[m]</i>	<i>Diameter [m]</i>
Tunnel_1	1	203	5.8
Tunnel_2	2	1455	5.8
Conduit	3	30	1.2
IntakeT1_1	4	20	1.2
Intake T1_2	5	1.5	0.8
Intake T2_1	6	25	1.2
Intake T2_2	7	1.5	0.6
Outlet T1	8	1.5	0.8
Outlet T2	9	1.5	0.6
Tunnel_3	10	460	3
Culvert	11	58	2

#### 3.2 Measurement Data

The measurement data of the Grunnåi hydropower plant has been retrieved using various monitoring systems and are taken from a several sensors installed at the power plant. There are hundreds of measured quantities from monitoring systems such as temperature, water pressure, etc. It is noted that not all measured quantities are relevant for the creation of simulation model. Relevant quantities, which provide the information for simulation model experiments, are water pressure, flow rate, generated power of turbines and nozzles opening values. According to these quantity names, the measurement name of available sensors in the power plant are extracted. Table 3 shows the available signals that were used for the simulation model. It consists of two data sets, *dataset 1* and *dataset 2*, which have been recorded at different points in time at different operation conditions of the hydropower plant. This means they have to be handled individually and have no cross-correlations but at the same time are close enough in time to not be affected by any structural changes due to ageing or maintenance done to the system. The measurement positions based on the element number of Figure 1 are shown in Table 2.

**Table 3.** Measured quantities

<i>Index</i>	<i>Name</i>	<i>Unit</i>	<i>Dataset</i>
7	Water flow rate	<i>m</i> <sup>3</sup> / <i>s</i>	1
7	Water pressure	<i>bar</i>	
T1	Generated power	<i>MW</i>	2
T1	5 Nozzles opening value	<i>%</i>	

For better understanding of the provided measurement data that will be used in simulation model, two datasets are shown in Figure 2 and Figure 3.

Note, due to the tolerances of the sensors used in the system being negligibly small compared to deviations caused by model inaccuracies, the measured values from Table 3 are considered as accurate and valid values and can serve as reference values against the results from sim-

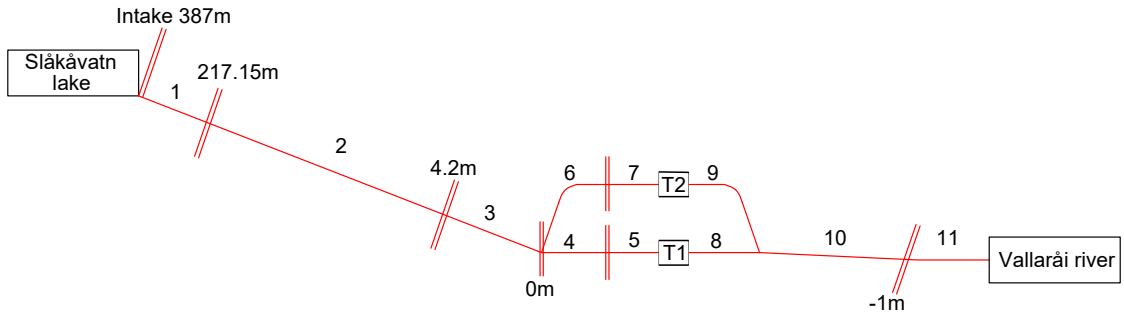

**Figure 1.** Overview of the structure of the Grunnai Power Plant

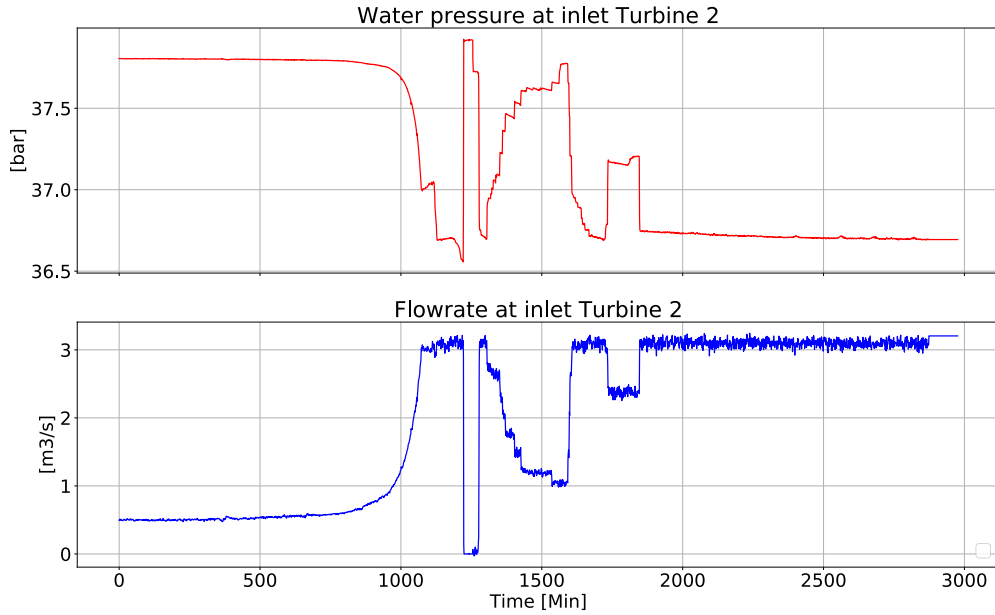

**Figure 2.** Measurement values of the dataset 1

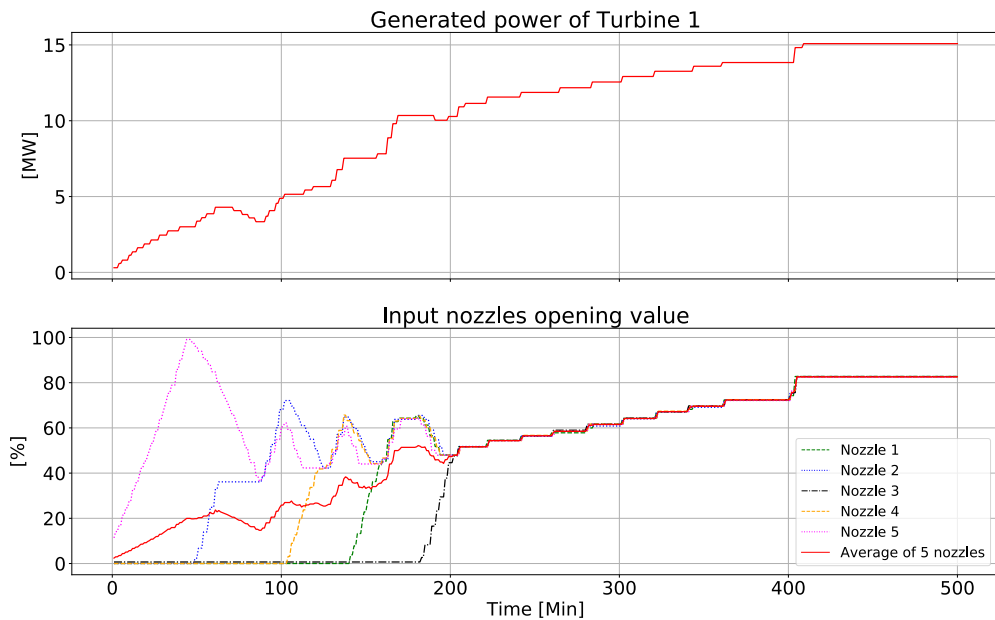

**Figure 3.** Measurement values of the dataset 2

ulation model.

## 4 Hydropower Modelling

In this section, a general description of the hydropower library OpenHPL is given as well the model of the Grunnåi power plant built based on this library is presented.

### 4.1 OpenHPL

OpenHPL is an open-source hydropower library that consists of hydropower unit models and is modelled using Modelica (Modelica Association 2021) and is available at (OpenSimHub 2022). This library is used to model hydropower systems of different complexity and connect them with models from other libraries, e.g., with models of the power system or other power generating sources. In this library, different waterway components of the hydropower system are described by both mass and momentum balance, and could include compressible/incompressible water. The mathematical models and methods used for the components in this library can be illustrated specifically in (Vytyvtskyi 2019). An overview of the structure of the hydropower library, OpenHPL is shown in Figure 4. For this simulation model of the Grunnåi hydropower plant the version 1.5.0 of OpenHPL has been used.

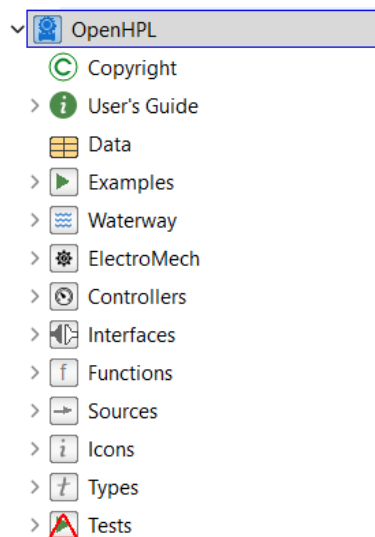

Figure 4. Screenshot of the structure of OpenHPL

### 4.2 Simple Model

According to general information of Grunnåi power plant given in Table 1, as well as the rough sketch of the structure as shown in Figure 1, a simple model of the hydropower plant was creating using the parameters settings from the Grunnåi power system. Figure 5 shows the simple model constructed for the simulation analysis.

## 5 Applying DoE for Simple Model Verification

This section describes the application of DoE to verify the simple model built based on the basic principles of DoE and the sequence of experiments is given.

### 5.1 Basic Principle

To verify the simple model, it is necessary to divide the simple model into parts and verify, optimise each part. This is where the blocking principle is applied. According to the structure of the hydropower plant (see Figure 1) and the available measurement data in Table 3, blocking divides the simple model into two main parts, the inlet system and the turbine system according to the two data sets. The inlet system consists of the elements from reservoir to water inlet pipe into the turbines (element “1” to “7” in Table 2) and the turbine system includes two turbine blocks with the main subject is “T1” according to the measurement data in Table 3 that is only available for “T1”. In the situation that there are several data sets, the principle of repetition and randomisation will be applied to iteratively divided parts according to the blocking principle under different operating scenarios of the hydropower plant. This is done in order to gain the experimental error estimation as well as confirm the final conclusion of experiments.

### 5.2 Sequence of Experiments

The verification experiments of the simple model have a sequence and cause-and-effect relationship. This means that the results of the previous part of model will directly affect the next part of the model. Therefore, setting up the experimental sequence plays an important role in the verification process of the entire simulation model. The inlet system will be simulated first to ensure the accuracy of flow rate into two turbines according to the relationship between flow rate and the generated power of the turbine. The parameters of the components in this part model are set according to the geometry data in Table 2, so these values are considered constant and cannot be adjusted. However, there is one parameter that deserves attention, which is the branching part of the water inlet (element “4” to “7”) shown in the simple model as the parallel connection between the inlet branch of “T1” and “T2”. The branching part will be experimented on using different connection components of the OpenHPL in order to find the most optimal component that represents the branching. After verifying the inlet system, the next step is to verify the turbine model. Since the turbine parameters are set up according to the provided general information in Table 3, the factors, five nozzles opening values that have main influence on the turbine model are investigated. At the beginning a *Trial Run* of the simple model is used where the average of the five nozzles vane opening values serves as an input signal to turbine model. This method needs to be verified again after having an effective inlet system. In case



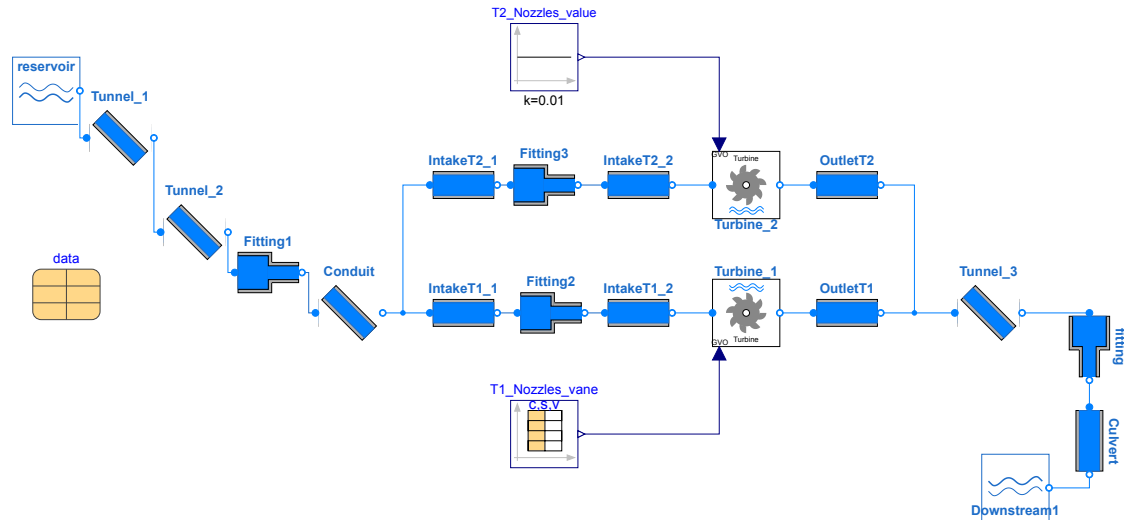

Figure 5. Simple model of hydropower plant modelled in Dymola using OpenHPL

that this method is not effective, a mathematical model between the generated power and the input signal, main vane opening value using Equation 1 will be constructed and the mathematical model will be verified by use of the simple model.

## 6 Experiments

The series of experiments on the simple model are implemented in order to verify and optimise the design. The sequence of experiments on the simple model is shown in Figure 6.

**Trial Run** First, a simulation trial was run to verify the accuracy of the built hydropower plant model by comparing the simulation results with the reference values in Table 3. This simulation trial is called *Trial Run* for which *dataset 2* was used. The input of the simulation model is the average opening value of five nozzles of T1 and the reference value of simulation results is the generated power of T1. Figure 7 shows the simulation results of the model comparing with the measurement values. T2 was deactivated for this *Trial Run*.

According to Figure 7, there is a difference between the simulation and measurement values which proves the inaccuracy of the simple model of the hydropower plant. This simple model needs to be verified and optimised which will now be shown following the DoE philosophy.

### 6.1 Experiment 1

**Objectives recognition** The objective of experiment is to determine the optimal design of branching part in the inlet system.

**Description** There are three different branching designs using components in OpenHPL library for the simulation model.

**Design 1:** Using basic connection same as the *Trial Run*.

This type of connection represents for water flow and contains the information about the pressure in the connector and mass flow rate that flows through the connector.

**Design 2:** Using “Fitting” component.

The “Fitting” component is modelled based on the functions defining the pressure drop due to different constrictions in the pipes. There are specify types of “Fitting” including: *Square*, *Tapered*, *Rounded*, *Sharp*, and *Thick*. These types require the diameter of the first and second pipes at the input and output of “Fitting”, which are used to calculate the pressure drop in the various fitting.

**Design 3:** Using “BendPipe” component.

The “BendPipe” component means the bend in pipes. This bend causes a pressure drop in the water flow caused by the loss coefficient parameter which can be obtained from manufacture’s information or guessed from the experimenters.

The information of the methodology and relevant equations modelling these components used in three designs is available in (Vytvytskyi 2019).

**Selection of response** The response of interest for the experiment is the water pressure at the inlet of T2.

**Selection of process variables** There are two variables in this experiment:

- The value of flow rate at inlet of T2 in *dataset 1*
- Three designs

**Performing the experiment** The experiment of Design 3 is implemented as Figure 8 and another designs, Design 1 and Design 2 are implemented similarly. The

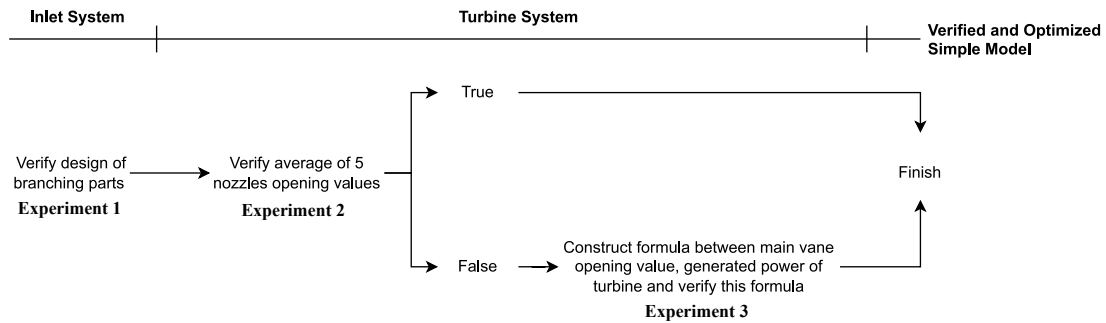

Figure 6. Sequence of experiments for simple model

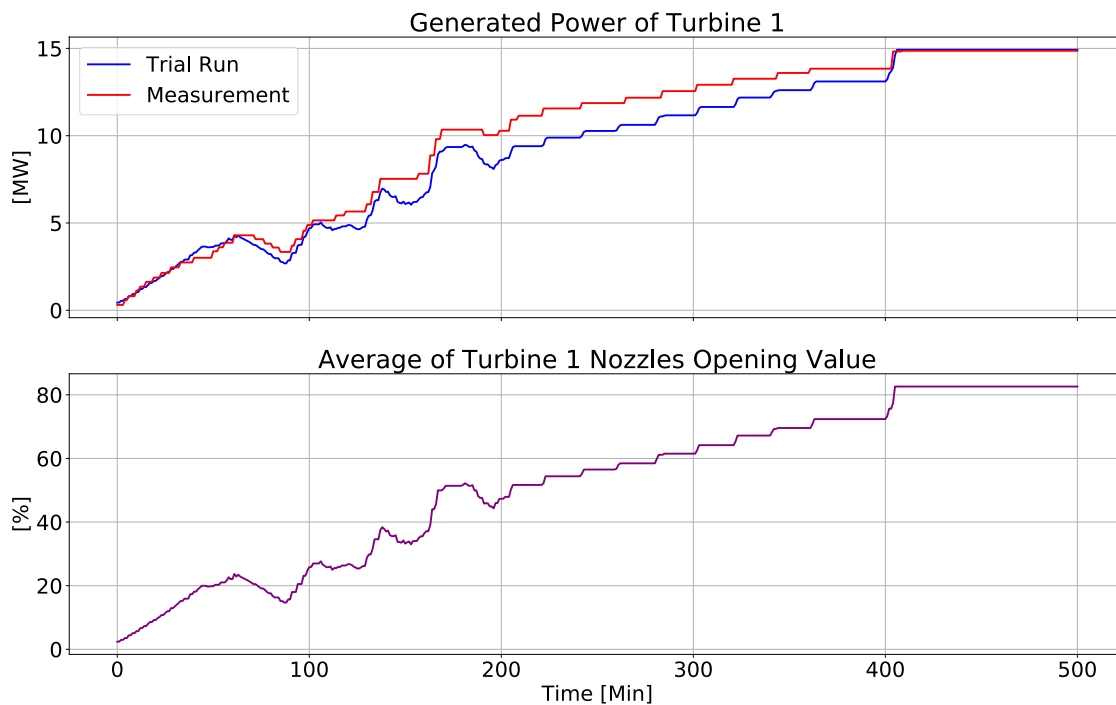

Figure 7. Comparison of the model simulation results and measurement values against change in averages of nozzle opening values

blocks named “T1” and “T2” are used to represent turbines without using turbine block models in the experiment since these models have not been verified. These blocks are used to input the measured flow values from the block “Data”. In Design 2, the parameter of component “Fitting” representing for the branching point is set up according to the diameter of “Conduit” and “IntakeT1\_1” that have the same diameter. The type of *Square* is used for this component. In Design 3, the parameter of component “BendPipe” is setup according to the diameter of “Conduit” and “IntakeT1\_1”. The authors in this paper recommended the loss coefficient parameter as 10 according to the lack of information from the manufacture.

**Interpreting experimental results and conclusions**  
The experimental results are collected and plotted in Figure 9.

According to Figure 9, the water pressure at inlet T2

varies due to the change of flow rate and it can be easily seen that the Design 3 shows the simulation results are nearly same as the measurement values as reference values in this experiment. Therefore, Design 3 with “bendPipe” component is considered the most optimal for branching part representation and also the model design of inlet system. The Design 3 will be used for the following experiments.

## 6.2 Experiment 2

**Objectives recognition** The objective of experiment is to verify the method of using average of five nozzles opening value as the input signal of the T1 model.

**Selection of response** The response of interest for the experiment is the generated power of T1.

**Selection of process variables** The process variables in this experiment are five nozzles opening values of T1 in

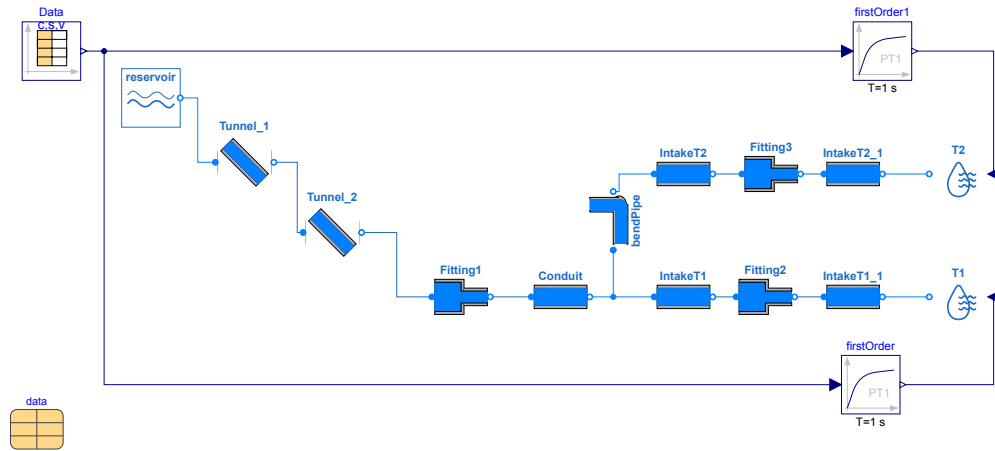

Figure 8. Experiment 1, simulation model

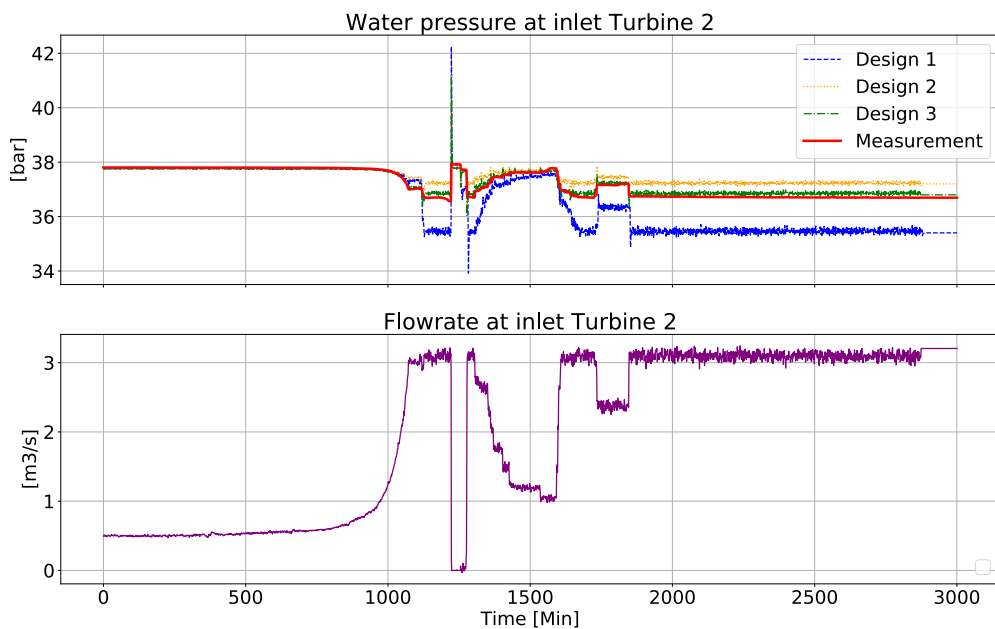

Figure 9. Experiment 1, comparison of the results of three model designs and measurement values against change in flow rate

dataset 2.

**Performing the experiment** The experiment is implemented same as Figure 5 with the inlet system as Design 3 in experiment 1 is used.

**Interpreting experimental results and conclusions** The experimental results are collected and plotted in Figure 10.

According to the results showing Figure 10, it illustrates the method of using average of five nozzles opening value as the input signal of the T1 model does not yield the desired improvement between the simulation results and the reference value for generated power of T1 when compared with the simulation results of the *Trial Run*. Therefore, the method of using average of 5 nozzles opening value is not suitable for the input values of the turbine model.

### 6.3 Experiment 3

**Objectives recognition** The following are the objectives of the experiment:

- to develop a mathematical model which relates generated power of turbine and the input signal value of turbine block, the main vane opening value
- to verify the mathematical model built on the simple model

**Selection of response** The response of interest for the experiment is the generated power of T1.

**Selection of process variables** The variables of this experiment are following

- The main vane opening value
- The generated power of T1



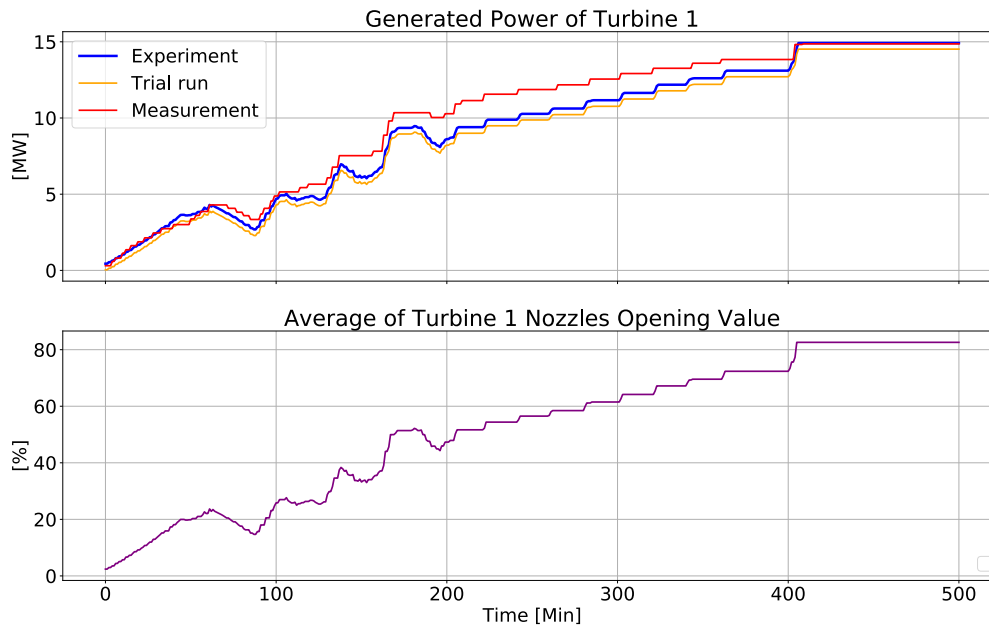

**Figure 10.** Experiment 2, comparison of the results of simulation model and measurement values against change in average of nozzles opening values

**Performing the experiment** The model to implement this experiment is same as that of Experiment 2. The implementation of building the equation showing the relationship between the input value of the turbine model, the main vane opening value, and the generated power of T1 can be performed in three steps:

**Step 1:** Run the simulation with the main vane opening value from 0% to 100% and obtain the generated power of T1 values.

**Step 2:** Export the data from simulation under CSV (Comma-separated values) format and import this file into Python (*Welcome to Python.org* 2022) environment via pandas (*pandas - Python Data Analysis Library* 2022) to analysis the data through Python commands.

**Step 3:** Apply `sklearn.linear_model.LinearRegression` package (*sklearn.linear\_model.LinearRegression* 2022) to create the mathematical model under the format of Equation 1.

According to these steps, the mathematical model (Equation 2) showing the relationship between generated power and main vane opening value is constructed. The generated power of T1 in *dataset 2* is used to calculate the opening value of main vane. Accordingly, this mathematical model is built in Dymola/Modelica as the component named “Uv\_T1” and applied in the simple model as Figure 11.

**Interpreting experimental results and conclusions**  
Mathematical model:

$$y = -0.003 + 5.57 \cdot 10^{-8}x \quad (2)$$

Where:

y Main vane opening value [%]

x Generated power of turbine 1 [MW]

According to the results showing Figure 12, it can be easily seen that the experimental and measurement values of generated power of T1 are similar. Therefore, the mathematical equation of generated power and main vane opening value is accurate.

## 7 Conclusions

The paper presents a simple hydropower plant model set up on Dymola/Modelica based on OpenHPL which is a specialised library to model a real hydropower plant. In the process of setting up a simulation model according to the elements in the library, the design model needs to be verified and optimised to suit the actual structure of a hydropower plant. This makes it difficult to choose the right design elements to optimise for the model. DoE is a distinct method in order to simplify the optimal solution for simulation model design based on experiments for the model. The principles and experimental steps of DoE are outlined and applied to a typical hydropower plant simulation model. With the available measurement data each portion of the model was simulated in turn to verify and optimise the design as well as eliminate noise factors. The result of the series of experiments and the completed simulation model will be used for research and further study cases.

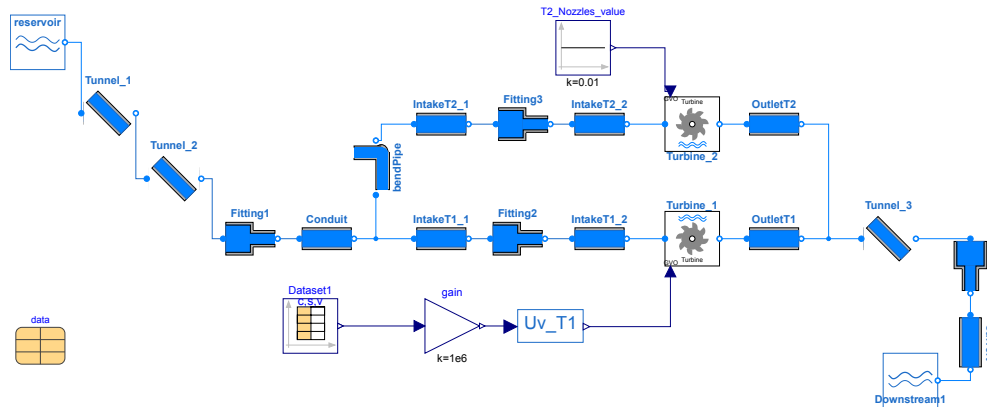

Figure 11. Experiment 3, simulation model

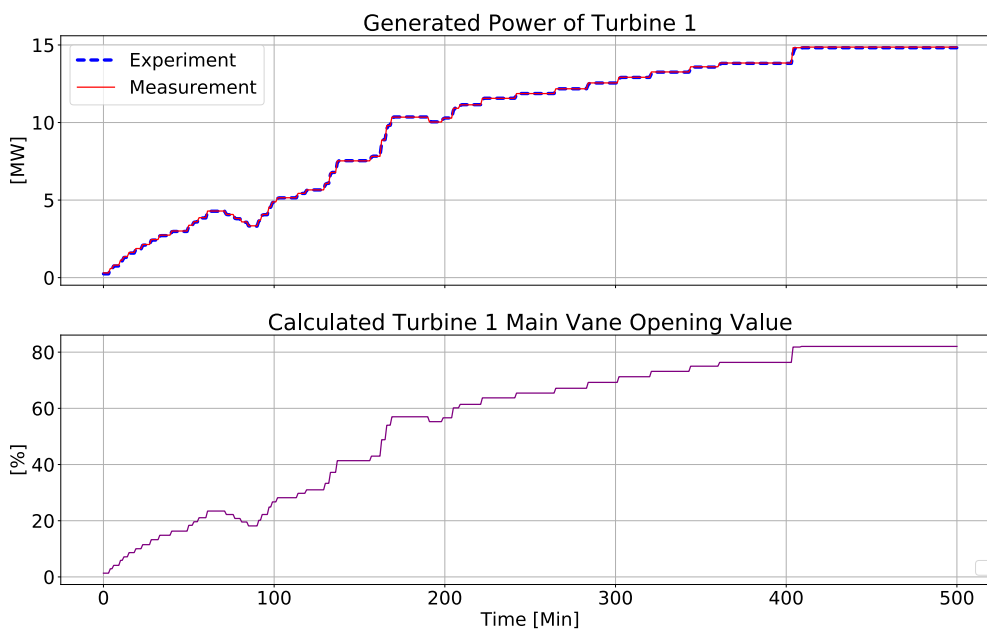

Figure 12. Experiment 3, comparison of the results of simulation model and measurement values against change in calculated main vane opening value

In practical situations of many complex systems with complicated chain of parts, these systems are commonly simulated by different simulation tools or software under vast amount data of operational data. However, the verification and optimisation of these simulation models always play an important role in studying characteristic of systems. This paper contributed to a simple solution to verify and optimise various type of simulation models in the future.

## Acknowledgements

This paper is the result of a Master's Thesis of Le Nam Hai Pham, with the title "Application of Design of Experiments for the Verification of a Hydropower Plant".

## References

- Antony, Jiju (2014). *Design of Experiments for Engineers and Scientists*. 2nd edition. Elsevier Insights. London: Elsevier. 208 pp. ISBN: 978-0-08-099417-8. URL: <https://doi.org/10.1016/C2012-0-03558-2>.
- Brownlee, Jason (2016-03-24). *Linear Regression for Machine Learning*. Machine Learning Mastery. URL: <https://machinelearningmastery.com/linear-regression-for-machine-learning/> (visited on 2022-04-12).
- eMathZone (2014-11-02). *Basic Principles of Experimental Designs* | eMathZone. URL: <https://www.emathzone.com/tutorials/basic-statistics/basic-principles-of-experimental-designs.html> (visited on 2022-04-12).
- Emily Divis et al. (2020-08-31). *Randomization: A Core Principle of DOE*. STAT COE-Report-03-2020. STAT Center of Excellence. URL: [https://www.ait.edu/stat/statcoe\\_files/1001AFIT2020ENS09115%201001divi%202-2.pdf](https://www.ait.edu/stat/statcoe_files/1001AFIT2020ENS09115%201001divi%202-2.pdf).

- Energy, Ministry of Petroleum and (2016-05). *Renewable energy production in Norway*. en-GB. Redaksjonellartikkel. Publisher: regjeringen.no. URL: <https://www.regjeringen.no/en/topics/energy/renewable-energy/renewable-energy-production-in-norway/id2343462/> (visited on 2022-08-08).
- International Energy Agency (2022). *Hydropower Analysis*. IEA. URL: <https://www.iea.org/reports/hydropower> (visited on 2022-04-12).
- Jankovic, Aleksandar, Gaurav Chaudhary, and Francesco Goia (2021-11). “Designing the Design of Experiments (DOE) An Investigation on the Influence of Different Factorial Designs on the Characterization of Complex Systems”. In: *Energy and Buildings* 250, p. 111298. ISSN: 03787788. DOI: 10.1016/j.enbuild.2021.111298.
- Kleijnen, Jack PC (1995). “Verification and validation of simulation models”. In: *European journal of operational research* 82.1, pp. 145–162.
- Modelica Association (2021-02). *Modelica a Unified Object-Oriented Language for Systems Modeling. Language Specification Version 3.5*. Linköping: Modelica Association. URL: <https://specification.modelica.org>.
- MoreSteam (2022). *Design of Experiments (DOE) Tutorial*. URL: <https://www.moresteam.com/toolbox/design-of-experiments.cfm> (visited on 2022-04-12).
- OpenSimHub (2022-04-01). *OpenHPL*. OpenSimHub. URL: <https://github.com/OpenSimHub/OpenHPL> (visited on 2022-04-12).
- pandas - Python Data Analysis Library* (2022). URL: <https://pandas.pydata.org/> (visited on 2022-05-05).
- Sargent, Robert G (2008). “Verification and validation of simulation models”. In: *2008 Winter Simulation Conference*. IEEE, pp. 157–169.
- sklearn.linear\_model.LinearRegression* (2022). en. URL: [https://scikit-learn/stable/modules/generated/sklearn.linear\\_model.LinearRegression.html](https://scikit-learn/stable/modules/generated/sklearn.linear_model.LinearRegression.html) (visited on 2022-08-13).
- Vytvytskyi, Liubomyr (2019). “Dynamics and model analysis of hydropower systems”. In: *Doctoral dissertations at the University of South-Eastern Norway*; 37.
- Welcome to Python.org* (2022). en. URL: <https://www.python.org/> (visited on 2022-07-28).