

Dynamic Modeling and Experimental Validation of Dishwasher with Heat Pump System

Erdoğan Mert Şeren¹

Mutlu İpek¹

¹Arçelik Global, Istanbul 34950, Turkey erdoganmert.seren@arcelik.com mutlu.ipek@arcelik.com

Abstract

Integration of heat pump systems with conventional dishwashers or household water heaters using electric heaters offers a promising solution to significantly reduce expected energy consumption. In this study, a comprehensive approach was undertaken to develop sub-models for each component of the heat pump dishwasher. These sub-models were subsequently integrated to form a complete cycle model of the heat pump dishwasher. The specific components modeled included the compressor, evaporator, condenser, and capillary tube. Furthermore, an algorithm model was devised to ensure the proper functioning of all the individual models, in accordance with the operational principles of the dishwasher. To validate the model, the temperature variation within the dishwasher during the heating and cooling phases was compared against experimental data. The maximum deviation observed in the cabinet temperature of the dishwasher was found to be ± 1 °C, with a corresponding deviation of 0.5 minutes in the cycle duration. Moreover, the maximum deviation in power consumption amounted to 2.4%, while a maximum deviation of 2.9% was noted in energy consumption. The results obtained from the model closely aligned with the experimental outcomes, thereby confirming its accuracy and reliability.

Keywords: Modeling of Heat Pump System, Dishwasher with Heat Pump, Algorithm, Modeling Validation, Dynamic Model, Dymola, Modelica

1 Introduction

Global warming has gained international attention, leading to climate change with altered weather patterns, rising sea levels, and increased extreme weather events. As the world economy recovers from the pandemic, greenhouse gas emissions are expected to rise. To tackle these challenges, the United Nations has set Sustainable Development Goals, and the European Union aims to reduce domestic greenhouse gas emissions by at least 40% by 2030, aligning with the Paris Agreement's goal of limiting global temperature rise to below 2 °C (European Commission, 2016).

The widespread use of household appliances such as washing machines, dishwashers, and refrigerators has resulted in significant environmental consequences due to their high per-unit emissions. To tackle this issue partially, integrating heat pump systems to household water heaters that employ electric heaters like dishwasher or washing machines presents a viable approach for substantially reducing energy consumption and mitigating the environmental impact associated with these appliances. To illustrate, Flück et al. (2017), investigated the heat pump system integrated in dishwashers and found out that it can lead to a significant reduction of up to 50% in electricity consumption compared to conventional electricity heaters. Atasoy et al. (2022) conducted a study where a heat pump water heater system was employed to replace a conventional electricity water heater for heating 4 liters of water to 50°C. The aim was to integrate it with household appliances such as dishwashers. The system was optimized by adjusting compressor speed and air flow rate through the evaporator. The optimized system was then compared to the conventional electricity water heater system, revealing a 17% decrease in energy consumption. On the other hand, the system modeling provides a means to understand system behavior and optimize its performance. It reduces the need for extensive experimentation, making it a valuable tool for system analysis and optimization. For instance, Caglayan et al. (2021) developed a comprehensive representation of a household refrigerator using Modelica, encompassing the intricate details of various parts such as the cabinet, compressor, capillary-tube, and control algorithm. Another research widening this study was conducted by Husain et al. (2023). In the study, a model created for a double-door refrigerator with a top-mounted configuration, featuring a serial refrigeration system. In addition to these, Ipek et al. (2023) proposed a dynamic model created in Modelica on upright freezer of refrigerator by investigating the periodic door opening cases with maximum 6% deviation on energy consumption value.

In the context of dishwasher models specifically, Caskey et al. (2018) built a dishwasher model on Modelica simulating an external hot water circulation instead of a conventional electric heater to demonstrate the potential energy savings. A novel methodology for the development and validation of a comprehensive model for a heat pump dishwasher was presented in this paper. The study introduced by constructing a detailed model of the dishwasher cabinet, capturing its structural and thermal characteristics. Subsequently, individual models of all heat pump components, including the compressor, condenser, evaporator, and capillary tube, were built to create a complete cycle model. Moreover, an algorithm model was developed, taking into account the dishwasher's cycle algorithm and its impact on energy consumption and performance and all models were associated with each other. Finally, the developed model was validated through experimentation under standard conditions. By means of this, the dynamic model serves as a valuable way for comprehending system dynamics and enhancing operational efficiency. By minimizing the reliance on extensive experimentation, it emerges as a potent tool for both analysis and optimization of systems.

2 System Design and Experimental Procedure

The heat pump system integrated into the dishwasher, located within the bottom chassis volume, comprises four key components: compressor, condenser, capillary tube, evaporator and R600a is used as the refrigerant. The main objective of the heat pump system is to heat the dishwasher's washing water. Upon activation, the refrigerant, at high temperature and high pressure, is discharged from the compressor and directed towards the condenser. The condenser facilitates efficient heat transfer, creating a hot surface for the purpose of heating. The secondary loop of the dishwasher, responsible for water circulation, is interconnected with the condenser through the heat pump system. In other words, the water passes continuously through the condenser, where it is efficiently heated. On the other hand, the refrigerant exits the condenser and flows through the capillary tube. Within this component, the refrigerant undergoes a decrease in pressure and temperature. It then proceeds to the evaporator, which is situated in front of an opening at the rear of the bottom chassis compartment of the dishwasher. It is in direct contact with the environment in which the dishwasher is placed. Through of fans located behind it, air drawn from the bottom chassis compartment is passed over the evaporator and released into the environment. This process enables the evaporator to draw heat from the environment.

Having absorbed heat in the evaporator, the refrigerant is subsequently directed back to the compressor, thus completing the cycle. Depending on the algorithm, the heat pump system remains active until the water reaches the desired temperature. Overall, the integration of the heat pump system in the dishwasher allows for efficient heating of the washing water, contributing to enhanced energy efficiency and performance. Table 1 provides the specific details of the dishwasher with a heat pump used in this study.

Table 1. Dishwasher with heat pump details.

Dishwasher with Heat Pump	
Dimensions (H x W x D)	818 x 598 x 550 mm
Place Settings	16 pcs
Water Consumption	9.9 L
Energy Consumption	470 Wh
Program Duration	190 min.
Compressor	Reciprocating
Condenser	Helical Tube
Evaporator	Fin and Tube
Refrigerant	R600a
Charge Amount	30g

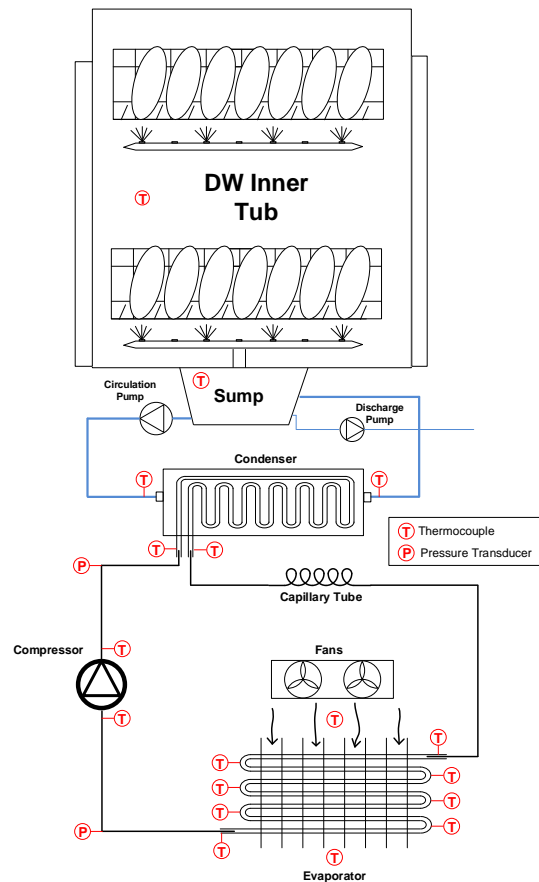

Figure 1. Schematic illustration of heat pump dishwasher.

With respect to the experimental procedure, the experiments are proceeded according to European dishwasher test standard EN 60436 (European Standard, 2020). Also, in order to find out system behavior, any number of thermocouple and two refrigerant high-low pressure transducers are added to the system. The system schematic is illustrated in Figure 1.

The experiments are conducted in a testing chamber in which the temperature and humidity are controlled fairly. When the dishwasher placed reaches the equilibrium temperature with the chamber then, it is operated, and the heating is taken place only by the heat pump system. Temperature, pressure, power, and energy consumption information are collected. The experiment is completed when the cycle is end off at which the water temperature reaches predetermined temperature. The accuracy of experimental results can be influenced by errors arising from measurement devices and the experimental setup. To assess the error values associated with calculated parameters derived from experimental data, various approaches have been suggested. One such method is uncertainty analysis, which was pioneered by Kline and McClintock (1953). Experimental accuracy values for temperature, voltage, current, power and energy consumption calculated by McClintock uncertainty approach are represented in Table 2.

Table 2. Uncertainties of experimental system

Sensor	Uncertainty
Temperature	± 0.5 °C
Voltage	$\pm 0.25\%$
Current	$\pm 0.25\%$
Power	$\pm 0.5\%$
Energy	$\pm 0.75\%$

3 Modeling Methodology

To create a dynamic model of a heat pump dishwasher, it is essential to model each component individually. These modeling studies are carried out using the Dymola software (Dassault Systems, 2021), which uses the Modelica language. While the dishwasher cabinet and its algorithm are modeled using the object-oriented Modelica language, the heat pump system is modeled from the TIL library with specific modifications. The library is developed by TLK-Thermo GmbH (2020) in Modelica modeling language that includes a created library containing various sub-libraries, such as fluid, gas, and refrigerant components. The complete model, represented by Figure 2, demonstrates the integration of

information-carrying components within their respective models, establishing interconnections between each model for a coherent system.

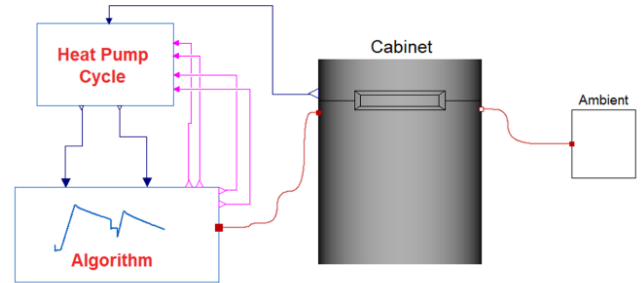

Figure 2. Dishwasher with heat pump model.

The heat pump system receives inputs from the cabinet and outputs to the algorithm model. Through the algorithm model, the water is heated, resulting in the cabinet being warmed via the connected heat ports. The algorithm's outputs are then communicated to the heat pump model, allowing the system to be controlled and operated according to the algorithm's instructions. Furthermore, the ambient model considers the ambient temperature and outer convection coefficient to simulate the heat transfer between the cabinet and the external environment. In the next sections, a comprehensive description of each component of the complete cycle model is provided in detail.

3.1 Cabinet Model

The cabinet of a dishwasher with a heat pump is of utmost importance due to its significant role in heat losses and energy consumption. The model's primary aim is to accurately estimate the heat loss through the cabinet walls to the surrounding environment and track the cabinet's air temperature over time. To reduce heat loss from the dishwasher's cabinet to the surroundings, the cabinet is constructed with multiple layers like insulation materials and bitumen. The heat transfer within the cabinet is modeled using a thermal resistance structure approach. Each material and component are divided into smaller segments to enhance the accuracy of the model.

The Figure 3 depicts the thermal resistance structure of dishwasher front wall. In this figure, the black resistance structures represent heat transfer through conduction, while the green resistances represent heat transfer through convection. Specifically, the "Outer Convection" resistance structure simulates the heat loss from the dishwasher cabinet to the surrounding environment, while the "Bottom Volume Convection" convection resistance represents the heat transferred to the bottom chassis volume.

Since one of the main objectives of the model is to observe the temperature inside the cabinet over time, the heat transfer mechanism needs to be calculated in a time-dependent manner.

To achieve the desired outcome, the one-dimensional time-dependent heat transfer equation along the wall is supposed to be solved. This equation is shown in Equation 1.

$$\frac{\partial^2 T}{\partial x^2} = \frac{\rho c_p}{k} \frac{\partial T}{\partial t} \quad (1)$$

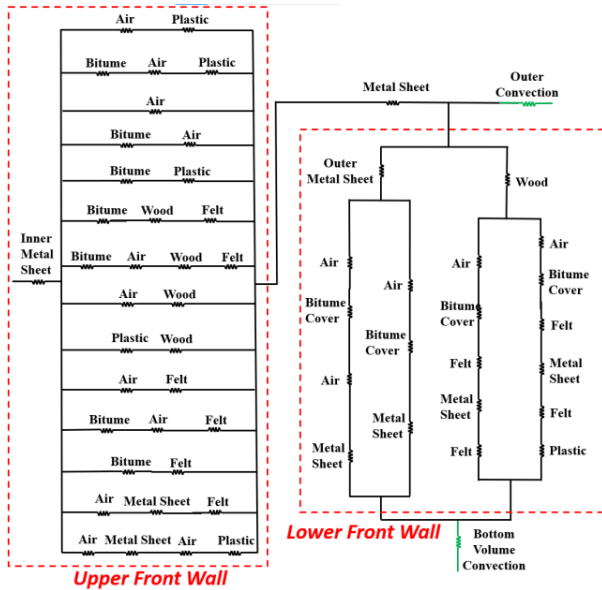

Figure 3. Thermal resistance structure of dishwasher's front wall.

A single resistance structure created in Dymola is demonstrated in Figure 4. This structure is used to construct each wall by connecting each other thermally, either in parallel or in series, based on the resistance structure created for each wall. Subsequently, properties such as thickness, area, density, specific heat capacity, and thermal conductivity are assigned to each resistance, depending on the material. By means of this approach, cabinet model was created and illustrated in Figure 5.

After constructing each wall structure, in addition to the resistance structures, dishes and other components that generate thermal loads within the cabinet are created as lumped masses in models indicated by numbers 3 and 4, respectively. These masses are thermally connected to the structure based on their materials and masses. On the other hand, since the heat pump system is located in the bottom chassis volume of the dishwasher, the operating conditions of the system are significantly

influenced by this volume. This is because the evaporator is directly fed by the air present in this volume. Therefore, the bottom chassis volume is also modeled within the bottom wall structure and provides feedback to the heat pump system model through the air temperature represented by number 5. Finally, the heat port indicated by number 1 is connected to the algorithm model to associate the heated water with the dishwasher cabinet, while the heat port represented by number 2 is thermally connected to the ambient model to simulate the heat loss from the cabinet to the surroundings.

To sum up, each individual resistance in the front wall resistance structure is represented in the model using a wall element. After creating the thermal resistance structures of all walls, like the front wall, they are individually created in the model using wall elements. Subsequently, each wall model is thermally connected to one another.

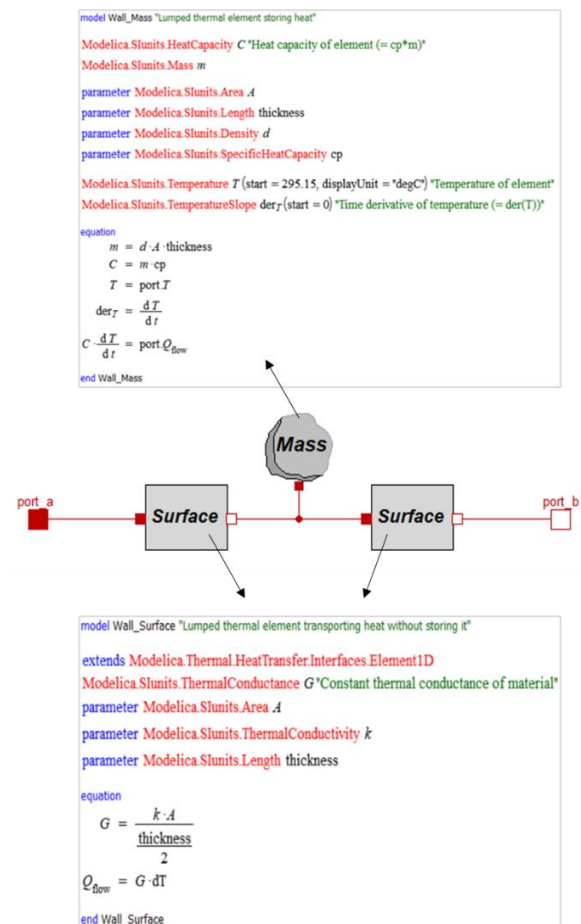

Figure 4. A wall element model created in Modelica Standard Library.

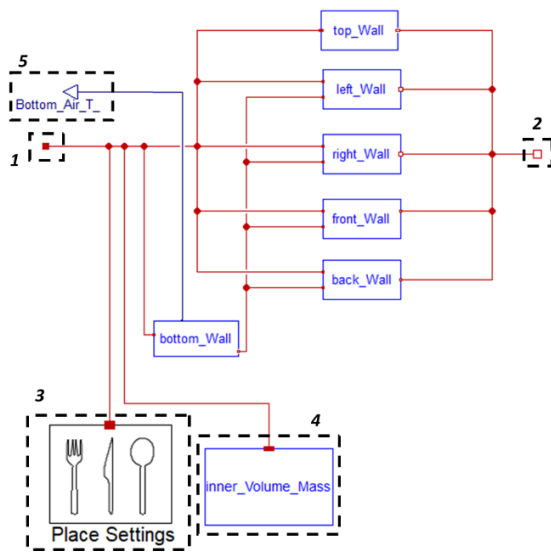

Figure 5. Dishwasher Cabinet Model in Dymola.

3.2 Algorithm Structure in Dymola

The complex algorithm of the dishwasher is primarily composed of two main steps, depending on the predetermined temperature value and time step. For example, during the main wash cycle, the water heating step is completed when the water reaches the desired temperature, while the cold rinse step operates based on the specified duration since there is no heating or specific water temperature set value. These two fundamental steps are reflected in the model by revising the "Timer" and "Trigger" models available in the logical library of Dymola shown in Figure 6.

The code revision allows the timer to run when the input is true and return false when the specified time period is over, providing flexibility in achieving the desired period independently of the simulation time. The trigger structure outputs a predetermined start value if the Boolean input is false and outputs the given input if it is true, enabling logical sequencing in the algorithm model. The water to be heated is modeled as a lumped mass, and different water models are used for each washing step.

The heating systems are controlled using the "timer" and "trigger" structures and associated with the cabinet structure. If the algorithm model is connected to a heat pump system, it can use the condenser capacity as the water heating capacity from that model. On the other hand, if a conventional heating analysis is desired, the heater capacity in the algorithm is inputted, and the water is heated accordingly based on this capacity. The algorithm model is communicated to both the cabinet and the heat pump model.

Power consumption by components such as circulation pump and compressor are known, allowing for dynamic power consumption and total energy calculation. The algorithm model is designed to be user-oriented by changing the time, temperature, and power parameter values out of the model, enabling simple parameter customization without interfering the code structure.

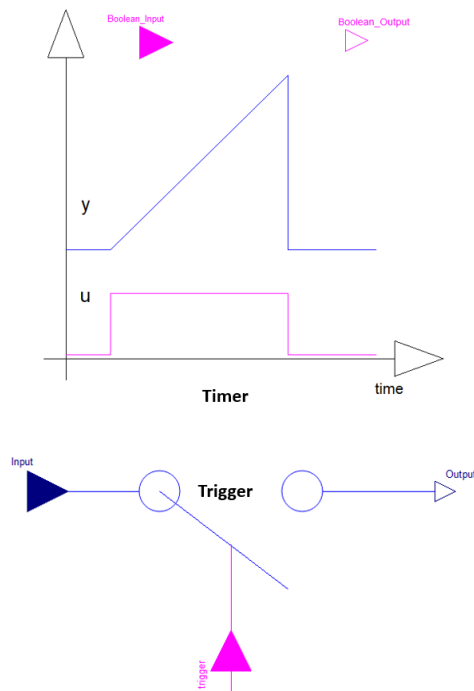

Figure 6. Algorithm components in Modelica Standard Library

3.3 Heat Pump System

The heat pump system located in the bottom chassis of the dishwasher enables much more efficient heating of the water compared to conventional heaters. To optimize the efficiency, it is crucial to ensure that all components of the heat pump system operate under optimal conditions. However, achieving this through experimental methods can involve significant workload and time. Therefore, modeling the heat pump system is vital, and system optimization, along with operating conditions, may be determined through parametric analysis on the model, which is much faster compared to experiments. In this context, each component of the heat pump system used in the dishwasher was individually modeled to create the heat pump system model by means of TIL Library introduced by TLK-Thermo GmbH.

3.3.1 Compressor Model

Reciprocating compressor model represented in the library is evaluated. The compressor is not considered as isentropic due to certain losses. For this reason, the model needs certain physical parameters simulating losses from the compressor. To illustrate, in order to simulate friction losses, friction coefficient parameters must be determined. They can be found by semi-empirical approach. Proceeding to the determination of these parameters, to begin with, compressor performance tests are completed in calorimeter system experimentally. In this test, input parameters which are condensation, evaporation, subcool, superheat and speed are assigned according to the working conditions of compressor in the system. Then outputs are achieved as cooling capacity, power consumption, mass flow rate and discharge temperature depending on working condition.

In parallel with this process, the compressor model tester is created in Modelica, therefore, input and output parameters are correlated with compressor model equations without any parameter assignation. Then the whole tester model is turned into FMU standardizing interface to be used in computer simulations to develop complex cyber-physical systems. Then it is imported to the ModelFitter (2022). Besides, the performance inputs and outputs obtained experimentally are introduced in ModelFitter. Thanks to statistical analysis, the physical parameters are estimated with R-square value of 0,95. Thus, physical parameters of the compressor model (heat losses, friction losses and so on) are calibrated depending on calorimetric measurements. So, the compressor model can calculate compressor power, mass flow rate, discharge temperature and capacity between at certain pressure levels.

3.3.2 Condenser Model

To create condenser model, the tube model in the TIL library is used and it is discretized as finite volume cells. For heat transfer coefficient governing heat transfer rate, correlations are used. In single phase region Dittus-Boelter (1985) correlation is used.

$$Nu = 0,023Re^{4/5}Pr^{1/3} \quad (2)$$

However, for two phase, convenient correlation is not found in the library and literature for helical type coil condenser. For this reason, two phase heat transfer coefficient is determined experimentally from water side by using thermal resistance approach and LMTD method (see in Figure 7). To attain water side heat transfer coefficient Gnielinski (1976) correlation is used. In detail, during the calculation process, the

condenser capacity of the heat pump system is determined by evaluating the enthalpy difference between the inlet and outlet of the refrigerant and multiplying it by the refrigerant flow rate. Subsequently, the capacity contributed by the single-phase region is subtracted from the total capacity to determine the capacity associated with the two-phase region. The convection coefficient on the water side is calculated using the Gnielinski correlation with known values of water inlet and outlet temperature, as well as water flow rate. The capacities of the water and two-phase refrigerant sides are equalized with each other and in this case, the two-phase heat transfer coefficient of refrigerant becomes the only unknown value. Also, the friction factor is determined based on the Moody diagram. The Gnielinski correlation and friction factor are shown in Equation 3 and 4.

$$Nu = \frac{\left(\frac{\zeta}{8}\right) (Re - 1000)Pr}{1.07 + 12,7\sqrt{\frac{\zeta}{8}}(Pr^{2/3} - 1)} \quad (3)$$

$$\zeta = 0.184Re^{-0.2} \quad (4)$$

On the other hand, geometrical parameters such as tube diameter, length and wall thickness are introduced to the tube model. In the cycle model obtained condenser capacity is considered for heating process of water.

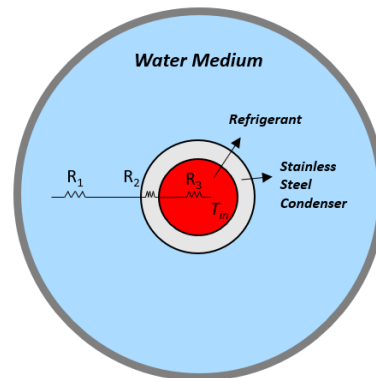

Figure 7. Condenser structure of dishwasher’s heat pump.

3.3.3 Capillary Tube Model

Capillary tube is also a component presented in the TIL library. The pressure drop in the capillary tube can be examined in two region, single phase and two phase. Since the refrigerant is in liquid phase at the inlet of capillary tube, pressure drop takes place linearly

depending on only friction. After certain point the first vapor bubble starts to form, and the refrigerant becomes two-phase state. In this region the pressure drop is non-linear and depends on both friction and momentum because of continuous density change of refrigerant. Pressure drop characteristic is represented by Navier Stokes equation and the friction term can be determined Swamee-Jain (1976) correlation. For fully developed flow, one dimensional Navier Stokes equation is shown in Equation 5.

$$\frac{dp}{dx} - \mu \frac{d^2u}{dy^2} = 0 \quad (5)$$

To illustrate, for two-phase region it is integrated along the tube, and it is described as in the Equation 6.

$$p \cdot \pi \cdot \frac{D^2}{4} - (p + \Delta p) \cdot \pi \cdot \frac{D^2}{4} - \tau_w \cdot \pi \cdot D \cdot \Delta L = m \cdot \Delta V \quad (6)$$

Also, the total pressure drop in the capillary tube is expressed as in the Equation 7.

$$\Delta p = \left[\left(\frac{f}{2D} \right) \Delta L + \frac{\rho_{in} - \rho_{out}}{\rho} \right] \cdot \frac{G^2}{\rho} \quad (7)$$

Lastly, Swamee-Jean correlation offering explicit solution to determine the friction factor in the pressure drop equation. The Swamee-Jean correlation is given as in the Equation 8.

$$f = \left[-2 \log \left(\frac{\epsilon/D}{3.7} + \frac{5.74}{Re^{0.9}} \right) \right]^{-2} \quad (8)$$

In addition, for single phase pressure drop inertia terms are neglected and pressure drop equation does not contain density change.

3.3.4 Evaporator Model

The heat exchanger in the form of a fin and tube structure, which is used as an evaporator in the system is also available in the TIL library similar to a tube structure. In this model, the Dittus-Boelter correlation is used when the refrigerant is in single-phase, while the Shah (1979) correlation shown in the Equation 9 is utilized for two-phase region. Additionally, for the air side correlation, the equation developed by Wang et al. (2002) specifically for the wavy fin structure is evaluated. Also, whole geometrical parameters such as number of serial and parallel tube distance, fin pitch, length and so on are introduced to the model depending on heat exchanger structure.

$$h = h_{liq} \left[(1-x)^{0.8} + \frac{3.8x^{0.76}(1-x)^{0.04}}{p_r^{0.38}} \right] \quad (9)$$

3.4 Dishwasher with Heat Pump Model

After individually modeling all the components of the heat pump system as mentioned in the previous sections, they are connected to each other to create a complete heat pump model. As seen in Figure 8, the compressor speed is controlled by a boundary condition. A tube model is used to simulate the heat transfer between the discharge, suction tubes and the surrounding environment.

Similar to the condenser, the dynamic temperature of the bottom chassis volume, which is generated in the cabinet model and increases during the experiment, is associated with the tube model through a resistance. Similarly, the bottom chassis temperature is used as the suction air for the evaporator, as it strongly influences the operating conditions of the evaporator and thus the heat pump system. Additionally, boundary conditions such as air flow rate are defined for the air-side boundary associated with the evaporator.

The behavior of the entire system is revealed through sensors, and the thermophysical properties of the refrigerant and air side are assigned using the System Information Manager model.

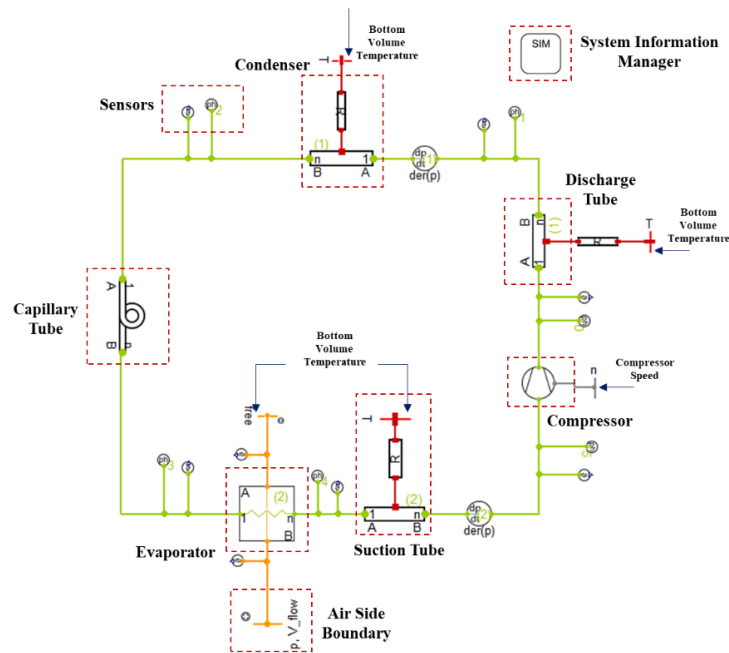

Figure 8. Whole heat pump model illustration in TIL Library.

4 Experimental Validation

After building the entire model, fine-tuning processes were conducted through experimental testing under standard conditions, European dishwasher test standard EN 60436. The fine-tuning parameters used included the thermal loss parameter, which simulated heat losses from the condenser surface to the cabinet, and the "tube roughness" in the capillary tube, which was adjusted to match the system pressure levels. In other words, each component should be fine-tuned before creating whole model. Because the real cases have always included chaotic circumstances. To illustrate, while validating heat loss from the dishwasher cabinet, the heat transfer between water circulated by spray arms hitting to the cabinet walls and cabinet walls cannot be predicted and calculated. On the other hand, the capillary tube in the heat pump system consists of tube roughness parameter excepting geometrical parameters, this parameter should be defined by far and away to converge pressure levels. For this reason, the model is in need of fine-tuning parameters like them. The fine-tuning primarily focused on optimizing the cabinet temperature and heating time. By adjusting these parameters, the model's accuracy and performance were improved to align with the experimental results. Subsequently, a comparative analysis was conducted between the model and experimental results of the base experiment, focusing on the temperature of the dishwashing cabinet, power consumption, energy consumption, and low-high

pressure values. This assessment aimed to ascertain the degree of agreement between the model's predictions and the actual measurements obtained during the experimental testing. The behavior of experimental and simulated cabinet temperatures is illustrated in Figure 9. Maximum experimental-simulation difference is ± 1 °C. In addition, the difference between the cycle time of the model and experiment is 0.5 minutes. The behavior of the model in the cabinet temperature is in line with the experimental outcomes.

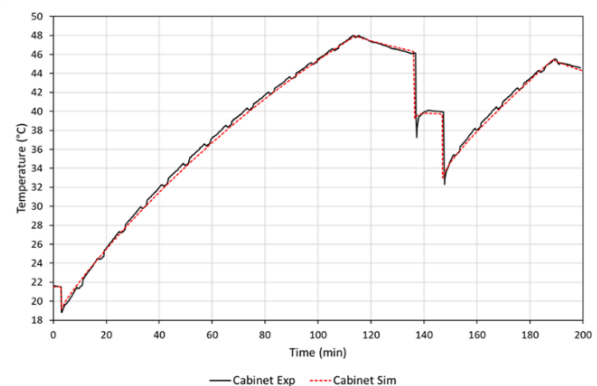

Figure 9. Cabinet temperature comparison.

Figure 10 illustrates the time-dependent power consumption during the dishwasher cycle. The power consumption is primarily influenced by the compressor,

circulation pump, and drain pump. The circulation pump operates throughout most of the cycle and its power consumption varies depending on the algorithm-driven spray arm positions and speeds. This variability leads to oscillations in power consumption. However, since the model calculates the average pump power consumption, this oscillation is not observed in the model. The average power consumption deviation during the cycle is 2.4%.

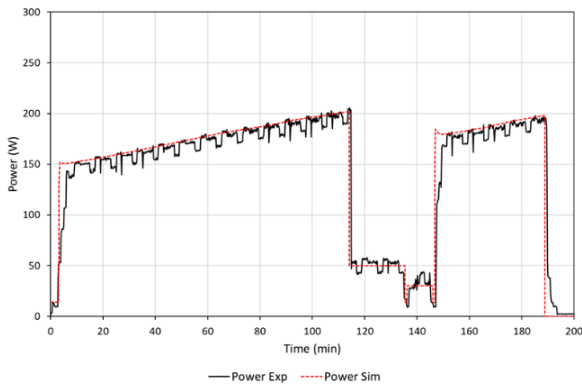

Figure 10. Power consumption comparison.

When comparing the model and experiment, it is observed that the model consumes more power than the experiment during the initial operation of the compressor. This difference can be attributed to the model's assumption of instantaneous evaporation temperature and the absence of accounting for the gradual increase in compressor speed for lubrication. In reality, it takes time for the refrigerant to reach the evaporation temperature, and the compressor gradually increases its speed. These factors result in a noticeable disparity in power consumption at the start of compressor operation. However, despite these variations, the overall trend in power consumption remains consistent between the model and experiment. The deviation in power consumption leads to a 2.9% difference in the overall energy consumption value.

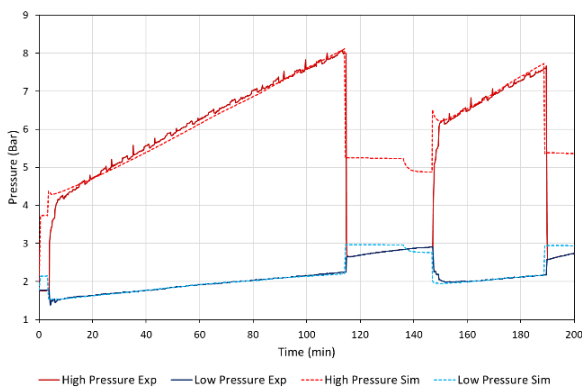

Figure 11. High- and low-pressure comparison.

The comparison between the model and experiment in Figure 11 shows that the model accurately predicts pressure drops and compressor performance along the capillary tube. However, there is a maximum inconsistency in the condenser pressure, with a deviation of approximately 0.23 bar, while it is 0.1 bar in the evaporation side. This difference is attributed to the use of fixed superheat values using the compressor model due to calorimeter limitations, while actual operating conditions may vary. Despite these discrepancies, the model fits the data well and allows for parametric analysis. It is important to note that numerical errors can explain significant deviations in the high-pressure results when the compressor switches on and off.

Following all validation procedures, the comparison between the model and experimental results for an entire cycle is presented in Table 3, providing the maximum deviations in cabinet temperature, power, energy, and high and low-pressure line values.

Table 3. Validation deviation results.

Cabinet Temperature	± 1 °C
Cycle Time	0,5 min
Power	2,4%
Energy	2,9%
High Pressure	0,23 bar
Low Pressure	0,1 bar

5 Conclusion

In this study, an object-oriented modeling methodology using the Modelica Programming Language has been presented for a dishwasher with heat pump. The study involves creating a sub model for each component of the heat pump dishwasher and then integrating all the models to obtain a comprehensive dynamic cycle model for the heat pump dishwasher. The cyclic behavior of the dishwasher has been experimentally validated. As a result, the developed dynamic model is able to respond parametric changes, by means of this, it could be used for optimizing processes. A prime example of this is that optimization studies for component and cabinet insulation sizing to increase system efficiency and reduce experimental effort.

Acknowledgement

The authors would like to express their sincere gratitude to Arçelik Global for their invaluable support throughout the course of this research. The contribution has been instrumental in the successful completion of this study.

References

- European Commission, “Communication from the Commission to the European Parliament and the Council Brussels. No. COM (2016) 110 final”, 2016, <https://eur-lex.europa.eu/> accessed on August 16, 2022.
- Flück, S., M. Kleingries, E. Dober, I. Gau, P. Bon, A. Loichinger and B. Wellig, “Household Dishwasher with a Monovalent Heat Pump System”, paper presented at the 12th IEA Heat Pump Conference, Rotterdam, 2017.
- Atasoy, E., B. Cetin and O. Bayer, “Experiment-based Optimization of an Energy-Efficient Heat Pump Integrated Water Heater for Household Appliances”, *Energy*, Vol. 245, p. 123308, 2022. doi: <https://doi.org/10.1016/j.energy.2022.123308>
- Caglayan, A., S. M. Husain, M. Ipek, T. N. Aynur, S. Cadirci, “Dynamic Modeling and Experimental Validation of a Domestic Refrigeration Cycle”, *Journal of Thermal Science and Engineering Applications*, Vol. 14, p. 071007, 2021. doi: <https://doi.org/10.1115/1.4052453>
- Husain, S. M., M. Ipek, A. Caglayan, T. N. Aynur, S. Kocaturk, H. Bedir, “Dynamic Modelling of The Steady State and Load Processing Operation of A Domestic Refrigerator Cooled Through Natural Convection”, *International Journal of Refrigeration*, Vol. 146, pp. 15-27, 2023. doi: <https://doi.org/10.1016/j.ijrefrig.2022.08.015>
- Ipek M., I. Dincer, “Experimental Investigation and Dynamic Modelling of an Upright Freezer Under Periodic Door Opening Conditions” *International Journal of Refrigeration*, 2023. doi: <https://doi.org/10.1016/j.ijrefrig.2023.06.004>
- Caskey S. L., E. A. Groll, “Dishwasher Modelica Model Analysis with an External Heat Loop” paper presented at the International High Performance Buildings Conference, Purdue, 2018. URL <https://docs.lib.purdue.edu/ihpbc/331/>
- EN60436, “Electric Dishwashers for Household Use – Methods for Measuring the Performance,” European Standard, 2020.
- S. Kline and F. McClintock, “Describing Uncertainties in Single-Sample Experiments”, *Mechanical Engineering*, Vol. 75, pp. 3-8, 1953. doi: [https://doi.org/10.1016/0894-1777\(88\)90043-X](https://doi.org/10.1016/0894-1777(88)90043-X)
- Dittus, F. W. and L. M. K. Boelter, “Heat Transfer in Automobile Radiators of the Tubular Type”, *International Communications in Heat and Mass Transfer*, Vol. 12, pp. 3-22, 1985. doi: [https://doi.org/10.1016/0735-1933\(85\)90003-X](https://doi.org/10.1016/0735-1933(85)90003-X)
- Gnielinski, V., “New Equations for Heat and Mass Transfer in Turbulent Pipe and Channel Flow”, *International Chemical Engineering*, Vol. 16, pp. 359-368, 1976.
- Swamee, P. K. and A. K. Jain, "Explicit Equations for Pipe Flow Problems", *Journal of Hydraulics Division*, Vol. 102, pp. 657-664, 1976.
- Shah, M. M., "A General Correlation for Heat Transfer During Film Condensation Inside Pipes", *International Journal of Heat and Mass Transfer*, Vol.22, pp. 547-556, 1979. doi: [https://doi.org/10.1016/0017-9310\(79\)90058-9](https://doi.org/10.1016/0017-9310(79)90058-9)
- Wang, C., Y. Hwang and Y. Lin, “Empirical Correlations for Heat Transfer and Flow Friction Characteristics of Herringbone Wavy Fin-and-Tube Heat Exchangers”, *International Journal of Refrigeration*, Vol. 25, pp. 673-680, 2002. doi: [https://doi.org/10.1016/S0140-7007\(01\)00049-4](https://doi.org/10.1016/S0140-7007(01)00049-4)
- TLK-Thermo GmbH. TIL3.9.1, 2020. URL <http://www.tlkthermo.com/index.php>
- TLK-Thermo GmbH. ModelFitter, 2022. URL <https://www.tlk-thermo.com/index.php/en/software/60-modelfitter>
- Dassault Systems, Dymola: Multi-Engineering Modeling and Simulation based on Modelica and FMI, 2021. URL <https://www.3ds.com/products-services/catia/products/dymola/>